

Operation and Maintenance Instructions

Bollard K12

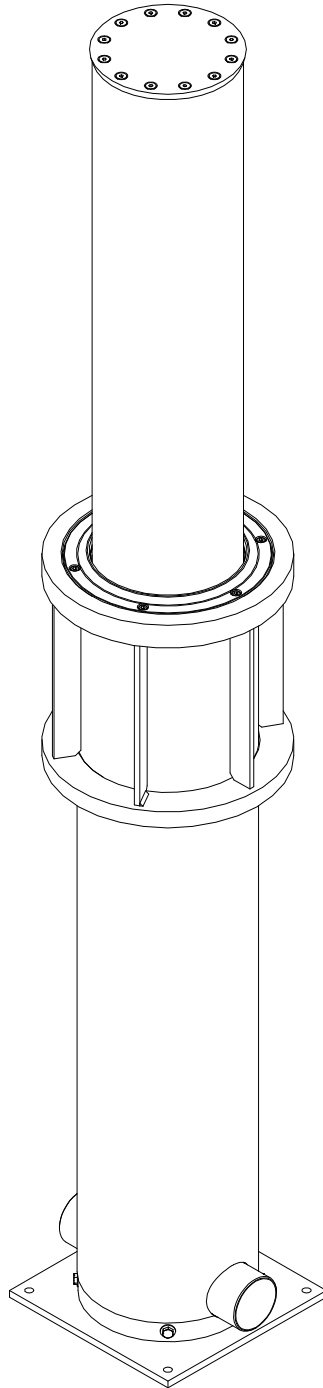

Table of Contents

1 GENERAL.....	3
2 SAFETY INSTRUCTIONS	3
3 BOLLARDS DESCRIPTION.....	4
3.1 BLOCKING ELEMENT.....	5
3.2 STANDPIPE.....	5
3.3 HYDRAULIC CYLINDER.....	5
3.4 LIMIT SWITCH	5
3.5 HYDRAULIC UNIT.....	6
3.5.1 OIL LEVEL / OIL TANK / OIL CHANGE	6
3.5.2 PRESSURE LIMIT VALVE (OPERATING PRESSURE).....	6
3.5.3 SOLENOID VALVE “MANUAL LOWERING WITHOUT POWER” (STANDARD).....	6
3.5.4 SOLENOID VALVE “AUTOMATIC LOWERING WITHOUT POWER” (OPTIONAL).....	7
3.5.5 ONE-WAY RESTRICTOR	7
3.6 ELECTRICAL CONTROL / CONTROL BOX	7
4 INITIAL OPERATION.....	8
4.1 FACTORY SETTINGS	8
4.2 OPERATION	8
4.3 WINTER OPERATION	8
4.4 EMERGENCY OPERATION.....	8
4.4.1 LOWERING IN MANUAL OPERATION (STANDARD)	8
4.4.2 AUTOMATIC LOWERING WITHOUT POWER (OPTIONAL).....	8
5 MAINTENANCE	9
5.1 MONTHLY MAINTENANCE BY THE OPERATING PERSONNEL	9
5.2 SEMI-ANNUAL MAINTENANCE.....	9
5.3 MAJOR MAINTENANCE.....	9
6 TROUBLE SHOOTING.....	10

1 General

The bollard is a vertically movable bollard. It is used for blocking and/or prevention of unauthorised travel on streets, ways or spaces.

With a multiple system up to three bollards at common drive unit can be connected in order to achieve a larger blocking width.

If necessary the bollard can be lowered until flush with the surface and then an unhindered access to streets, ways or spaces is possible.

2 Safety Instructions

All personnel who are applicable for the operation of the bollard, including back up personnel, must be thoroughly familiar with the operation and safety regulations.

This applies in particular to the adherence of the safety and control regulations as well as the intended use.

Any maintenance and repairs must only be implemented by certified technical personnel.

In order to avoid accidents the following points must be considered:

No persons and/or vehicles are allowed into the area over the blocking element when the bollard is functional.

The closing element must be extended early enough that approaching vehicles can still stop in time.

If the bollard functions are activated with neglect to the afore mentioned points the manufacturer cannot be held liable for any damages that may result to any person and/or property.

3 Bollards Description

The principal components of the bollards are:

- blocking element (1) with guard rail,
- standpipe set in concrete (2),
- inlaying hydraulic cylinder (3),
- drive cabinet with hydraulic unit and electrical control / control box

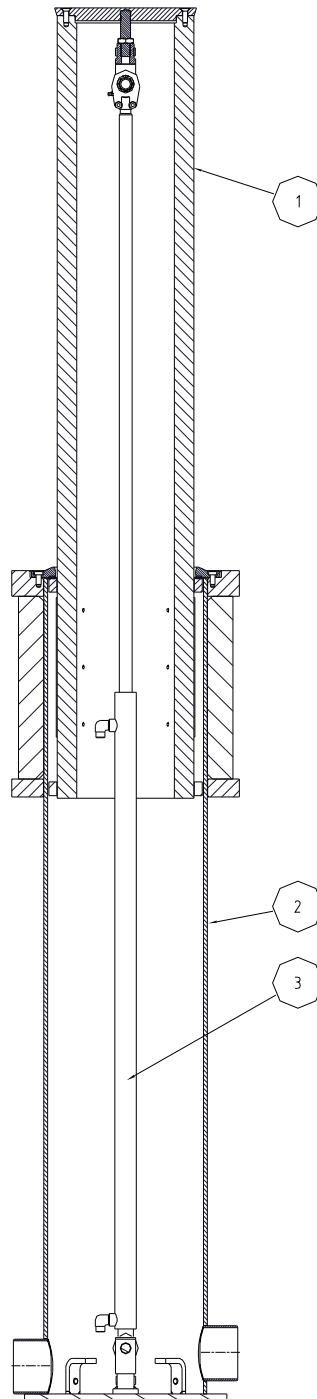

3.1 Blocking Element

The blocking element (1) can be vertically moved.

The guard rails are spread evenly and fastened to the blocking element pipe. They allow for a controlled raising of the blocking element. The blocking element is locked with a cover.

3.2 Standpipe

The standpipe (2) is a prefabricated assembly unit which is intended to be set in concrete. The standpipe is used for the reception and guidance of the blocking element.

The standpipe unit consists of the following parts:

- standpipe,
- base plate, screwed,
- cable conduit,
- drainage pipe connection,
- cover, screw on type

3.3 Hydraulic Cylinder

The hydraulic cylinder (3) is used to retract and extend the blocking element and is controlled through a drive (hydraulic system).

It is connected above through a fork head with the blocking element cover and under through a bearing with the base plate. Hydraulic hoses connect the cylinder with the hydraulic unit.

The cylinder bearing is bolted to the base plate using threaded bolts. A fastener for the limit switches is attached on the outside of the cylinder.

3.4 Limit Switch

When the extended and/or lowered position of the bollard is reached the hydraulic unit is switched off through the limit switches.

Both limit switches are attached to a fastener on a unmoveable external pipe of the hydraulic cylinder.

- End position: lowered blocking element

The vertical limit switch checks the contact to the blocking element cover. When the blocking element is lowered the limit switch has contact via a switching gap to the cover and switches off.

- End position: raised blocking element

The horizontal limit switch checks the contact to the blocking element pipe. During the entire raising process the limit switch has contact over a switching gap to the pipe. This switches off only when the blocking element has extended and a hole in the pipe is at the height of the limit switch.

The limit switches are factory adjusted!

The switching gap can be adjusted, step by step, by loosening the counter nuts on the limit switch and then shifting the limit switch. The following switching gaps are to be kept:

- vertical limit switch: approx. 20 mm (blocking element lowered)
- horizontal limit switch: approx. 5 mm (blocking element extended)

After completion the counter nuts should be adjusted and firmly tightened in order to prevent a self-loosening of the limit switches.

3.5 Hydraulic Unit

The hydraulic unit is implemented in the drive cabinet and consists of the following components:

- oil tank with integrated hydraulic pump,
- oil-filler neck,
- oil-drain plug,
- pressure gauge,
- solenoid valve (230V) “raise”,
- solenoid valve (230V) “lower”,
- pressure limit valve,
- solenoid valve (24V) “lower without power” (optional)
- one-way restrictor

3.5.1 Oil Level / Oil Tank / Oil Change

The oil level in the oil tank is checked using an oil dipstick. The oil level should always be within the mark. If the minimum stage is reached refill with approx. 2.5 litres hydraulic oil.

Before the initial operation make sure that the oil level is filled to the maximum mark.

filling quantity: approx.30 Litre

hydraulic oil: Plantohyd 22 S – NWG (biodegradable) or
 HLP 22 (mineral oil)

ATTENTION: Only use the same type of hydraulic oil as was used in the first filling!

The **oil tank** comes from the factory already filled with oil.

Hydraulic oil can be filled into the oil tank by unscrewing the oil filler neck.

There is an oil drain plug in the oil tank which allows one to change the oil. When this is unscrewed the oil runs out into the prepared catchment tank.

3.5.2 Pressure Limit Valve (Operating Pressure)

The pressure limit valve controls the operating pressure of the bollards. The operating pressure can be read on the pressure gauge.

If a correction is necessary (e.g. for winter operation), then the pressure relief valve at the knurled screw should be adjusted.

The necessary tools for this are an open-jawed spanner for an M8 (A/F13) and a screwdriver.

Operating pressure approx. 50-60 bar

3.5.3 Solenoid Valve “Manual Lowering without Power” (Standard)

The solenoid valves cause a raising and lowering of the bollards depending upon the current admission.

They are characterised as follows:

raise Y1,

lower Y2

Depending on the power admission the following functions of the bollards are reached:

- | | | |
|---------|---------------|-------------------------------|
| - Y1+Y2 | currentless, | = bollard movement standstill |
| - Y2 | under current | = bollard lower |
| - Y1 | under current | = bollard raise |

3.5.4 Solenoid Valve “Automatic Lowering without Power” (optional)

The solenoid valves cause a raising and lowering of the bollards depending upon the current admission. The additional third valve ensures the automatic lowering of the bollard with power failure using its own weight.

They are characterised as follows:

- | | |
|--------------------|-----|
| raise | Y1, |
| lower | Y2, |
| automatic lowering | Y3, |

Depending on the current admission the following functions of the bollards are achieved:

- | | | |
|-------------------------|------------------|-------------------------------------|
| - Y1+ Y2 without power, | Y3 under current | = bollard movement standstill |
| - Y2 and | Y3 under current | = bollard lower |
| - Y1 and | Y3 under current | = bollard raise |
| - Y1+ Y2 and | Y3 currentless | = automatic lowering of the bollard |

3.5.5 One-Way Restrictor

The one-way restrictor is used to regulate the drive out speed of the bollards. It can be adjusted, step by step, using the knurled screw.

With a multiple system the individual one-way restrictors are to be adjusted in such a way that when the bollards move upwards they remains approximately even to each other up to the end position. When the end position of the last bollard is reached then the hydraulic unit is switched off via the limit switch.

3.6 Electrical Control / Control Box

The control box is located in the electrical control. It is equipped with:

- reversing switch,
- motor overload switch
- transformer, (only with optional lighting)
- strip terminal,
- controller fuse,
- running time monitor,
- main switch,
- control lifter,

4 Initial Operation

4.1 Factory Settings

The bollards are factory tested in continuous operation. All electrical, hydraulical and mechanical functions were checked.

The bollards are delivered in faultless condition and are adjusted ready for operation. The following steps were conducted at the factory:

first fill up of the hydraulic unit with hydraulic oil.
setting the operating pressure on approx. 50-60 bar.
setting the one-way restrictor to regulate the drive out speed of the bollards.
setting the switching gap of the limit switch to reach the extended and/or withdrawn position of the bollards.

4.2 Operation

- retain factory settings
- check the hydraulic oil level
Before start-up the oil level must be on the upper marking (maximum).
- Activate the main switch and the corresponding functions sequence of the programmed control begins. Visually examine all movement sequences.

4.3 Winter Operation

It must be made certain that during heavy snow falls the blocking element is thoroughly cleared so that the normal functions of the bollards is ensured.

This must be done without the use of road salt. Instead wooden sliders or a wooden scraper should be used.

4.4 Emergency Operation

4.4.1 Lowering in Manual Operation (Standard)

In normal operation the bollard is extended (blocking position). In order to be able to lower the bollard during a power failure the following steps must be performed:

- remove the cover from the drive housing,
- open the ball cock on the solenoid valve,
- blocking element lowers through its own weight

4.4.2 Automatic Lowering without Power (Optional)

In normal operation the bollard is extended (blocking position). That means the hydraulic cylinder is extended and the solenoid valve Y3 is under current and is thereby closed.

Therefore the pressure is maintained and the bollard remains extended. During a power failure the solenoid valve Y3 is currentless and opens. Using its own weight the bollards lowers itself automatically via the Y3 valve.

5 Maintenance

Before the maintenance work can begin all safety precautions must be adhered to. **See the Safety Instructions chapter!**

The cover must be removed in order to perform the maintenance work on the bollards. (see assembly instructions).

5.1 Monthly Maintenance by the Operating Personnel

The following points are to be visually examined:

- Bollard
 - a) Clean any contamination on the annular gap between the bollard and the cover of the standpipe
 - b) Check the extended blocking element for damages, e.g. impact, allow damage repair
 - c) Check for faultless bollard movement and pay attention to any unusual noises

- Drive Unit
 - a) Check the hydraulic screws, oil tank and hydraulic units for leakage
 - b) Check the intactness of the hydraulic hoses
 - c) Check the oil level (level should be within the mark)
 - d) Check the intactness of the cover seals

5.2 Semi-Annual Maintenance

The semi-annual maintenance is to be performed by a machine specialist. It covers the visual examination as described under Point 1 and the following additional work:

- Blocking Element
 - a) Clean the entire blocking element
 - b) Unscrew the blocking element cover and check the hydraulic cylinder mounting as well as checking the tightness of the electrical limit switches
 - c) Check the piston rods and hydraulic cylinder hose connections for leakage (use a torch / flashlight)
 - d) Check the approximate synchronisation of the bollard drive-out movement in multiple systems, if necessarily adjust the speed at the one-way restrictor.

- Standpipe
 - a) Clean cover and interior, within reach, of any contamination
 - b) Check the drainage connection, if necessary remove any blockage
 - a) Determine the degree of pollution on the bottom of the standpipe. With large soil accumulation, particularly in the building phase, cleaning may be necessary.

- Drive Unit
 - a) Clean the dust and dirt from the entire hydraulic unit.
 - b) Check the operating pressure, if necessary adjust the pressure release valve (approx. 50-60 bar)

5.3 Major Maintenance

The major maintenance should be carried out by a machine specialist after 1,000 operating hours or at the very latest every 2 years. The machine specialist must have knowledge of hydraulics.

In addition to the work contained in the regular maintenance service the following must be performed:

- a) Check all functional parts, connections and screws for intactness and tightness
- b) Change the hydraulic fluid
- c) Perform function test, if necessary readjust
- d) Check of the control by an electrical specialist, check the condition of the control and faultless operation of the electrical components

6 Trouble Shooting

ATTENTION: Please keep in mind the safety instruction before beginning to work!

- Problem: blocking bollard extends too slowly

-because of air pockets in the hydraulic system
deerate the system

-operating pressure too low
adjust pressure relief valve

-adjust the one-way restrictor

- Problem: bollard does not extend / does not sink

-check if the blocking element is free (no objects or vehicles)
Free the blocking element

-check if the annular gap between the blocking element and cover is free
remove objects and/or contamination

-check if the blocking element is damaged (deformed)
repair the blocking element, Technician needed

-no power
emergency operation to lower the bollard
(optional: hand pump to extend the bollard)

-power present
check oil level, if necessary refill oil
check operating pressure, if necessary correct
check pump, if necessary replace
check solenoid valve function, replace valve

- Problem: hydraulic unit does not switch off when the end position is reached

-switching gap between the limit switch and push button is too large,
adjust