

Product Sheet

Tornello DL 600 Tripod Turnstile for internal installation

Technical Specification

Drive: Hand operated

Orientation: Pass Left or Pass Right

Materials: Casework: 304 Grade Stainless Steel or Painted Steel RAL 7032.

Casework Lid: 304 Grade Stainless Steel

Tripod Hub:: Aluminium Alloy painted black.

Tripod Arms: Stainless Steel tube, polished
Diam. 35 mm, walkway 480/500 mm

Function: Passage in both directions, electronically controllable

Mechanism: Control of the Tripod operation is achieved by an electro-mechanical head mechanism located within the top section of the turnstile casework. It is silent in rotation and comprises the following standard features: -

- A positive lock action that prevents two passages at one time
- A self centering mechanism to ensure complete rotation of the mechanism to the home position
- A hydraulic damper to ensure smooth operation and longer mechanism's life
- Anti backup device to prevent reverse rotation once the mechanism has moved 60° from home

Operating Modes: When go signal is given from the access control system or from a push-button, the tripod can be rotated for 120°, allowing the passage of only one person at a time.

Power Failure: In the event of isolation of the power supply, the tripod can be configured to fail-safe (SMT), i.e. rotates freely, or fail-lock (BMT), i.e. locks in the home position. Either option is available in both or one direction.

Interface: The HE84/3 control logic has the following standar features:

- One input for opening/locking the mechanism in each direction (voltage free contact required)
- Two 0V output relays indicating availability of use in either direction
- Two 0V outputs to count passage in either direction .

The Unit has an adjustable time out facility if required i.e. Go signal will be cancelled if passage through turnstile is not completed within pre-set time.



Product Description

The DL600, compact, simple and elegant, is highly requested above all in applications where the space availability is limited and the required security level is not very high.

Users include

- Government
- Retail
- Finance
- Telecommunications
- Information Technology
- Banking
- Publishing
- Leisure
- Petrochemical
- Education

TRIPOD TURNSTILE

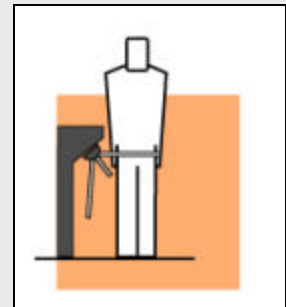

Power Supply:	115/230V AC 50/60Hz
Max Power Rating:	50VA
Logic Voltage:	24V dc
Delivery Details:	DL600 is delivered fully assembled and may require lifting gear for off loading. DL600 weight is approx 60 kg .

Available models

Turnstile DL 600

- TM00543 model Wall-mounted model in painted steel
- TM00544 model Wall-mounted model in grained stainless steel AISI 304
- TM00543 + AT51100 model Painted steel model with upright support
- TM00544 + AT51200 model Grained stainless steel AISI 304 model with upright support

Accessories

Cardreader Mounting (Please refer to Gunnebo Italdis for feasibility)

- Surface mounting only of customer supplied readers
- Cardreader Pedestals

Traffic-lights

- LED trafficlights are available to give availability to transit in a specific direction.

Remote Control

- MP20 Control Module: to set turnstile operation modes (free, locked or controlled by card reader)
- Single entry push-button

Key Selector

- Key installed on Turnstile that allows the selection of the operating modes (free, locked or controlled by card reader)

Counters

- Electromechanical or LCD counters to count people entering or exiting the Turnstile.

Drop Arm

- In the event of an emergency or isolation of the power supply the horizontal tripod arm will drop automatically to create a clear walkway for escape.

Anti-panic Device

- The horizontal tripod arm can be folded in the exit direction when a force is applied. This allows people escape in case of panic.

Fail- safe Configuration

The turnstile can be configured in the Factory in order to allow free passage in case of power failure.

Installation examples



Site Preparation DL600

(for wall-mounted model please request installation drawings to Gunnebo Italdis SpA)

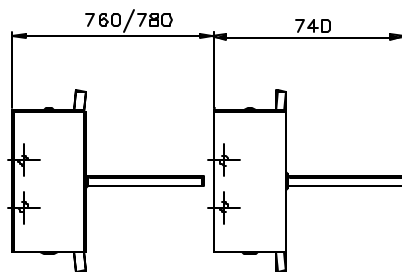
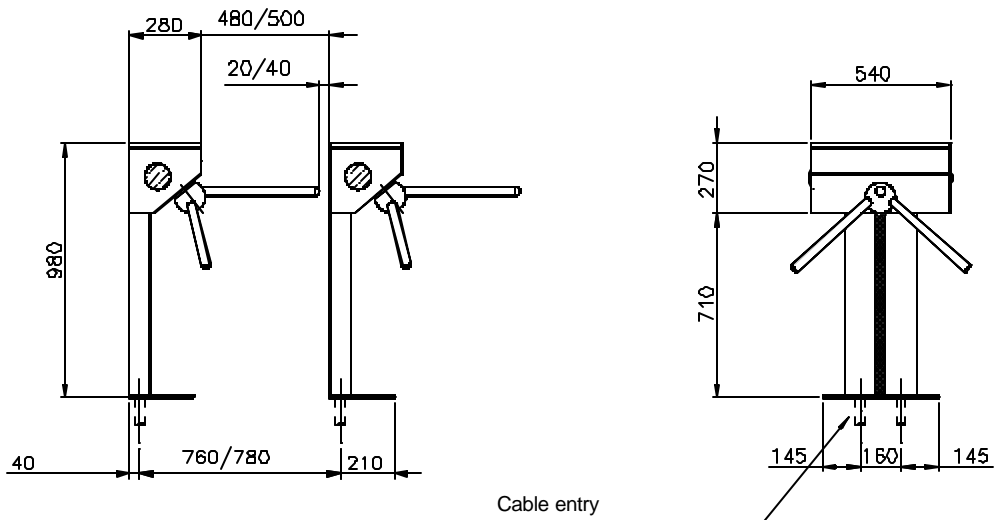

Floor anchor position (drilled during installation).

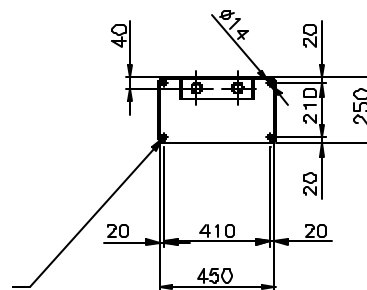

Wall-mounted version

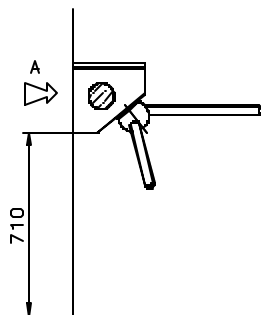

Cable entry

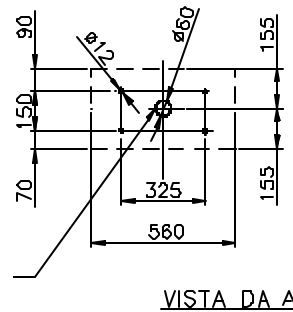

VISTA DA A

Concrete to UNI 9858, tipo RCK250.
Base to be flat and level to +/-5mm over footprint area

IMPORTANT

- Any horizontal pipe or conduit runs below the DL600 must be at least 140mm below.
- The dimension reported on this Product Data Sheet are for information only. In order to prepare the Installation Site, please refer to the lay-out drawings prepared by Gunnebo Italdis SpA or ask confirmation.

Flow Rates

Reader Device	Number per minute
Insertion type	20
Insertion type with PIN code keypad	10
Swipe type	30
Swipe type with PIN code keypad	12
Proximity 'Hands Free'	40

- Please note the figures are approximate and must be confirmed with Gunnebo Italdis SpA.
- Figures quoted are for one person per complete passage per walkway and per minute.
- It is assumed the access control authorisation response is instantaneous.



ITALY

Gunnebo Italdis SpA, Via A Volta 15 - IT 38015, Lavis (TN)
 Tel +39 0461 248 900 Fax +39 0461 248 999

Gunnebo Italdis SpA, Via Torri Bianche, 9 – IT 20059, Vimercate, (MI)
 Tel +39 039 685 95 11 Fax +39 039 685 95 24

www.gunneboitaldis.com

Note: In pursuit of its policy of continuous refinement and improvement, Gunnebo Italdis SpA reserves the right to modify design and details.

A COMPANY WITHIN THE GUNNEBO GROUP

HEAD OFFICE SWEDEN – Gunnebo Entrance Control AB, SE590 93, Gunnebo.
 Tel +46 (0) 490 89000, Fax +46 (0) 490 23889

DENMARK Gunnebo Protection A/S
 Division Entrance Control
 Erhvervsparken 3, DK-4621 Gadstrup
 Tel +45 46 19 14 66
 Fax +45 46 19 14 55

FRANCE Gunnebo Entrance Control SARL
 Zone d'Activites Le Mandinet,
 20 Rue des Campanules
 F-77185, Lognes
 Tel +33 (0) 1 64 80 14 40
 Fax +33 (0) 1 64 80 14 39

GERMANY Gunnebo Entrance Control GmbH
 Diagonalstrasse 41, D-20537
 Hamburg
 Tel +49 (0) 40 47 11 30 0
 Fax +49 (0) 40 47 11 30 79

HONG KONG Gunnebo Entrance Control
 Room 2312, C.C. Wu Building,
 302-308 Hennessy Road, Wanchai.
 Tel +852 2882 8337
 Fax +852 2523 7880

ITALY Gunnebo Italdis SpA
 Via A Volta 15 -IT 38015
 Lavis (TN)
 Tel +39 0461 248 900
 Fax +39 0461 248 999

NORWAY Gunnebo Troax A/S
 Division Entrance Control
 Postboks 179, Kalbakken N-0903, Oslo
 Tel. +47 22 80 42 00
 Fax +47 22 80 42 01

SPAIN Gunnebo Entrance Control
 BBC, Comte d'Urgel 143, lola 08036,
 Barcelona
 Tel +34 93 452 59 56
 Fax +34 93 451 56 53

SWEDEN Gunnebo Entrance Control
 Box 500, Kumla Gardsvag 33F, 145 63
 Norsborg
 Tel +46 (0)8 53 17 15 75
 Fax +46 (0) 8 53 18 85 39

UNITED KINGDOM Gunnebo Mayor Ltd
 Bellbrook Business Park, Uckfield,
 East Sussex, TN22 1QQ
 Tel +44 (0) 1825 761022
 Fax +44 (0) 1825 763835

USA Gunnebo Omega Inc
 5056 Commercial Circle, Suite E,
 Concord, California, CA 94520
 Tel +01 925 609 6339
 Fax +01 925 603 0810