

HiSec9

Security Booth for Internal or Semi External Use

Technical Specification

Drive:	Motorised						
Orientation:	Walkway functions as both Entry and Exit						
Materials:	<table> <tr> <td>Framework:</td> <td>40 x 10 x 3mm RHS mild steel</td> </tr> <tr> <td>Cladding:</td> <td>4mm mild steel, wet spray painted, textured finish to Gunnebo Entrance Control Ltd RAL colour selection.</td> </tr> <tr> <td>Glazing:</td> <td> <ul style="list-style-type: none"> • Lite - 13mm Laminate Safety Glass. (6mm Glass / 0.75mm Interlayer / 6mm Glass) • Bullet Proof - 27mm Laminate Safety Glass - C2 specification. (AP/B-AC/A to UNI 9186-9187 standards) </td> </tr> </table>	Framework:	40 x 10 x 3mm RHS mild steel	Cladding:	4mm mild steel, wet spray painted, textured finish to Gunnebo Entrance Control Ltd RAL colour selection.	Glazing:	<ul style="list-style-type: none"> • Lite - 13mm Laminate Safety Glass. (6mm Glass / 0.75mm Interlayer / 6mm Glass) • Bullet Proof - 27mm Laminate Safety Glass - C2 specification. (AP/B-AC/A to UNI 9186-9187 standards)
Framework:	40 x 10 x 3mm RHS mild steel						
Cladding:	4mm mild steel, wet spray painted, textured finish to Gunnebo Entrance Control Ltd RAL colour selection.						
Glazing:	<ul style="list-style-type: none"> • Lite - 13mm Laminate Safety Glass. (6mm Glass / 0.75mm Interlayer / 6mm Glass) • Bullet Proof - 27mm Laminate Safety Glass - C2 specification. (AP/B-AC/A to UNI 9186-9187 standards) 						

Standard Colours: Black - 9005, Grey - 7001, Blue 5010, Brown - 8019 and Red - 3000.
Please note that the colour of the moving doors framework is always black

Function: Passage in both directions, electronically controllable.

Mode of Operation: The doors are always locked shut in the rest position. An authorised signal opens the first door allowing the user to step into the booth where a presence is detected via means of checking weight increase on the floor, side panels and doors. The first door then closes and the second door opens, thus allowing the user to pass through. The second door shuts after the unit has been vacated which also resets the system.

Prevention of Multi Person Entry: Electronic weight sensing determines if more than one person is present within the booth. The booth is set with a predetermined, but adjustable anti hostage threshold (upper and lower weight limit) of 120Kg as standard. As an authorised user stands in the booth, it confirms acceptance of the occupant and authorises the door to close. Should the measured weight not be authorised, i.e. more than one person present or over weight non-permitted additional baggage, a vocal synthesiser will ask the occupants to leave the booth. Once the occupants have vacated the booth the door will close and the system will automatically reset.

Standard upper and lower weight limits range from between 1 - 140Kg. For heavy requirements a maximum setting of 160Kg is also available.

Any object left inside the booth will be detected during the reset sequence. An alarm will be activated and the object will have to be removed by manually opening the secure side door. 250grms min.

Passage Confirmation: As authorised passage occurs the doors open and close in sequence. To confirm this operation separate outputs are given for each door as it closes to confirm the movement of the occupant from one side of the booth to the other.

Battery Back Up: Battery Back Up is supplied as standard. It will allow the booth to operate on continuous cycle of approx. 2 hours, if batteries are fully charged and maintained.

Power Failure: In the event of a power failure, isolation or after the BBU has been depleted, the outer, un-secure door will fail safe, i.e. un-locked and can be manually pushed open. The inner, secure door will fail lock and is held in place via a lever system situated behind a locked panel above the door on the secure side of the installation. The inner door can be manually opened by rotating a knob located behind the lockable service panel in the top mechanism section of the booth.

Emergency: In the event of emergency a signal can be sent to the booth controller to command either, the secure, non-secure or both doors to open.
Fire Alarm – Input facility available for OV contact supplied by others to effect the specified emergency fail state.



Product Description

The HiSec9 security booth offers the highest level of access control with presence, passage and weight detection as standard.

The HiSec9 is also suitable for wheelchair security access.

Users include

- Head Offices
- Banking
- Computer Suites
- Telecommunications
- Information Technology
- R and D
- Government
- Military
- Security Publishing
- Law Enforcement

Control



Safety: Both leading and trailing door edges and framework are fitted with pneumatic safety edges that reverse the motor to re-open the door upon detection of an obstruction. The door fully opens to allow the obstruction to be removed after which it attempts to re-close, should the obstruction remain it will repeat the opening and closing sequence for sixty seconds after which time the booth controller 'times out' and sounds an alarm on the remote console. (One remote console is supplied as standard.)

The torque setting of the door leaf is set at 8 to 12Kg, when a higher value is detected the leaf will slow down, stop and automatically reverse to the full open position. The motor is also fitted with over current protection should an obstruction be detected.

Should a person remain within the booth for longer than sixty seconds, with the power switched off, the non-secure door will automatically open to allow the person to vacate the booth.

Intercom: Mounted as standard on all models.

Interface: The booth is controlled via a microprocessor activated by 0V contacts provided by a combination of either, card reader, push button or radar device. As standard the following features are available:-

- Eight inputs
- Eight 0V programmable outputs of which three are used for entry, exit and passage confirmations.
- Two remote consoles.
- Alarm contact for telephone.
- One serial port for RS232.

Note - The interface program can be customised, therefore it is important to confirm all interface requirements when placing an order.

Power Supply: 115 or 230V AC 50/60Hz

Power Rating: 330VA max.

Control Voltage: 24V dc

Installation: Internal or Semi External (under canopy), 150mm is required over the top of the booth for non routine maintenance/adjustment. Secure demountable over panel required if installed on wall centreline for access to electrical mechanical components during servicing.

Servicing: Standard servicing is from the secure side of the booth via a lockable panel above the secure door.

Temperature Range: -10°C to 55°C

Delivery Details: The standard HiSec9 range is delivered fully assembled and will require specialist lifting gear for off loading. Dependent upon specification the weight of the booth ranges from 1000 to 1300Kg, therefore sufficient access space must be made available from the point of off loading to installation locality.

Model	Nett Weight (Kg)	Packed Weight (Kg)
HiSec9	770	1020
HiSec9LM	810	1060
HiSec9B	1000	1250
HiSec9BM	1040	1290

Installation Examples

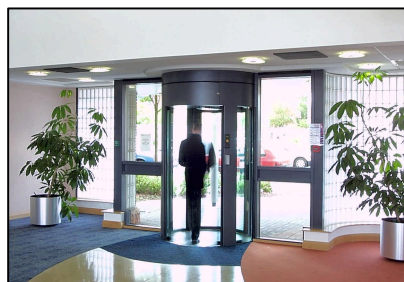

Models Available

HiSec9 Security Booth:

- Model HS9L Electrically controlled in both directions, 13mm 3 ply Safety Glass, Weight Sensing, Internal Light and Remote Console.
- Model HS9LM Electrically controlled in both directions, 13mm 3 ply Safety Glass, CEIA PN8 Metal detection, Weight Sensing, Internal Light and Remote Console.
- Model HS9B Electrically controlled in both directions, 27mm 3 ply Bullet Proof Glass , Weight Sensing, Internal Light and Remote Console.
- Model HS9BM Electrically controlled in both directions, 27mm 3 ply Bullet Proof Glass, CEIA PN8 Metal detection, Weight Sensing, Internal Light and Remote Console.

Standard Accessories and Optional Extras

Alternative Materials, Finishes and Custom Design (Please contact Gunnebo Entrance Control Ltd for suitability and costs)

- Casework available in other materials, i.e. Stainless Steel, Brass etc.
Note - A lacquered finish is recommended for some materials,i.e. Brass, please contact Gunnebo Entrance Control Ltd Technical department for more information.
- Other paint colours and finishes.
- Alternate glazing specifications.

Cardreader Mounting (Please refer to Gunnebo Entrance Control Ltd for feasibility)

- Casework surface mounting of card readers.(Card readers are customer supplied)
- Cardreader Pedestals.

Push Button Control

- Simple remote Push Button Console.
- Remote console to specific requirements.
- Single pushbutton casework mounted.

Demountable Casework.

- Delivered in part assembled components for site assembly that allows the unit to be positioned in areas of restrictive space. Additional assembly site time should be allowed for assembly of the unit and the fixing of the claddings to the internal steel support frame. (When ordering suffix standard code with a D to denote demountable option.)

Model	N ^o Packages	Total Packed Weight (Kg)
HiSec9D	2	1370
HiSec9LMD	2	1410
HiSec9BD	2	1600
HiSec9BMD	2	1640

Metal Detection:

- Should an attempt be made to enter the booth with a weapon or metal object similar in size, it will be identified and the secure door will be inhibited from opening. The non-secure door will remain open and the vocal synthesiser will request the occupant to leave the booth. After the occupant has left the door closes and resets the system ready for a new passage. (CEIA PN8 fitted as the standard option.)

Weight Banding (Please refer to Gunnebo Entrance Control Ltd for feasibility)

- A user is allocated to a predetermined weight band , as they stand in the booth the weight sensing gives a digital output to the access control system that verifies acceptance of the user. The access control system confirms acceptance and gives an output signal to the booth to shut the door and activate the operation sequence. Should the measured weight not be authorised, i.e. more than one person or unauthorised additional baggage a vocal synthesiser will request the occupant/s to leave the booth. A maximum of eight weight bands is available, ranging from 1 to 140Kg.

• Band 1	1 - 55Kg	Band 2	56 - 65Kg
• Band 3	66 - 75Kg	Band 4	76 - 85Kg
• Band 5	86 -100Kg	Band 6	101 - 115Kg
• Band 7	116 - 130Kg	Band 8	131 - 140Kg

The facility can also be achieved via a serial connection.

This option is subject to suitability of the access control system, please contact Gunnebo Entrance Control Ltd Technical Department for assistance.

- Additional weight band interface to transmit digital data in analogue form.

Site Preparation HiSec9 Range

Model HiSec9

Model HiSec9 with Metal Detection

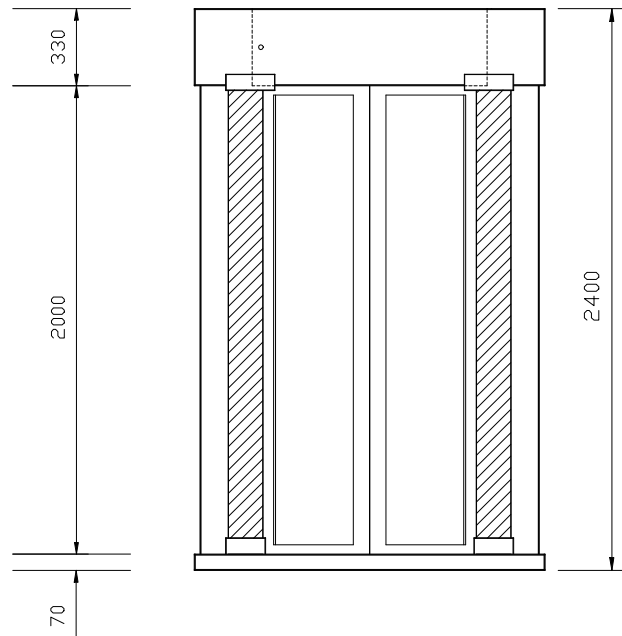
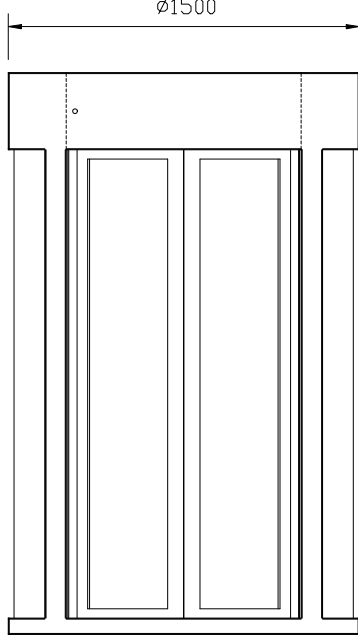
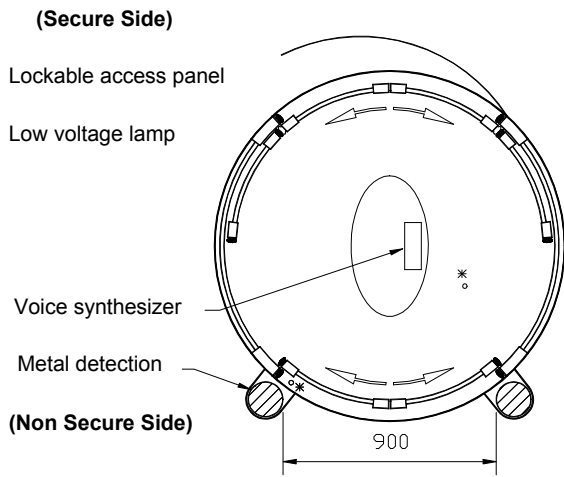
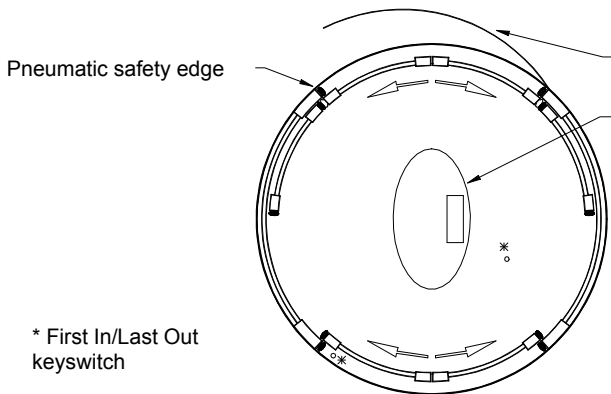

Bottom cable entry
30mm dia.

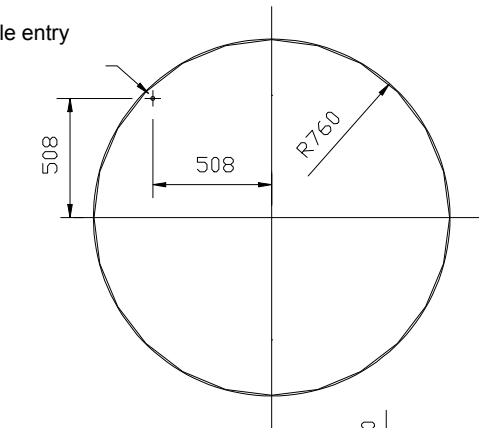

Floor Recess Details

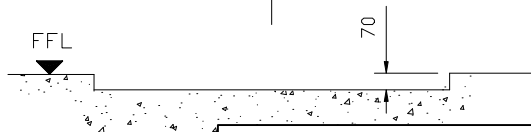

Concrete to BS 5328: 1997 specification, type ST5. Base to be flat and level to +/-5mm over footprint area. To level unit during installation use non-metallic shims only.

IMPORTANT

- Any horizontal pipe or conduit runs below the HiSec must be at least 140mm below FFL.
- It is the customers responsibility to ensure the structural integrity and strength of the installation location.

Flow Rates

Reader Device	Number per minute
Insertion type	3
Insertion type with PIN code keypad	2.5
Swipe type	3
Swipe type with PIN code keypad	3.5
Proximity 'Hands Free'	4

- Please note the figures are approximate and must be confirmed with Gunnebo Entrance Control Ltd. Figures quoted are for one person per complete passage per walkway and per minute. It is assumed the access control authorisation response is instantaneous. Flow rates will increase with multiple passage use.

GUNNEBO

ENTRANCE CONTROL

United Kingdom

Gunnebo Entrance Control Ltd. Bellbrook Business Park, Uckfield, East Sussex, TN22 1QQ.
Tel +44 (0) 1825 761022 Fax +44 (0) 1825 763835

www.gunneboentrance.com

Note: In pursuit of its policy of continuous refinement and improvement, Gunnebo Entrance Control Ltd reserves the right to modify design and details.

A COMPANY WITHIN THE GUNNEBO GROUP

HEAD OFFICE SWEDEN

Gunnebo Entrance Control AB, 590 93 Gunnebo, Tel +46 (0) 490 890 00, Fax +46 (0) 490 23889

DENMARK Gunnebo Protection A/S
Division Entrance Control
Erhvervsparken 3, DK-4621 Gadstrup
Tel +45 46 19 14 66
Fax +45 46 19 14 55

FRANCE Gunnebo Entrance Control SARL
Zone d'Activites Le Mandinet,
20 Rue des Campanules
F-77185, Lognes
Tel +33 (0) 1 64 80 14 40
Fax +33 (0) 1 64 80 14 39

GERMANY Gunnebo Entrance Control GmbH
Diagonalstrasse 41, D-20537
Hamburg
Tel +49 (0) 40 47 11 30 0
Fax +49 (0) 40 47 11 30 79

HONG KONG Gunnebo Entrance Control
Room 2312, C.C. Wu Building,
302-308 Hennessy Road, Wanchai.
Tel +852 2882 8337
Fax +852 2523 7880

ITALY Gunnebo Entrance Control SpA
Via A Volta 15 - IT 38015
Lavis (TN)
Tel +39 0461 248 900
Fax +39 0461 248 999

NORWAY Gunnebo Troax A/S
Division Entrance Control
Postboks 179, Kalbakken N-0903, Oslo
Tel +47 22 80 42 00
Fax +47 22 80 42 01

SPAIN Gunnebo Entrance Control SL
BBC, Comte d'Urgel 143, lola 08036,
Barcelona
Tel +34 93 452 59 56
Fax +34 93 451 56 53

SWEDEN Gunnebo Entrance Control
Box 500, Kumla Gardsvag 33F, 145 63
Norsborg
Tel +46 (0)8 53 17 15 75
Fax +46 (0) 8 53 18 85 39

UNITED KINGDOM Gunnebo Entrance Control Ltd
Bellbrook Business Park, Uckfield,
East Sussex, TN22 1QQ
Tel +44 (0) 1825 761022
Fax +44 (0) 1825 763835

USA Gunnebo Omega Inc
535 Getty Court, Suite F, Benicia
California, CA 94510
Tel +1 707 748 0885
Fax +1 707 745 6020